

2 - Hood

CODE	DESCRIPTION
150819	CABLE HOLDER PG16 WITH HOLE
160772	PLUG FOR DOOR (BR-BC-FC)
160804	GASKET D.6
160838	SLIDING WASHER TIE ROD FC
160840	WASHER
160905	SLIDING PLATE F. TIE ROD
180506	DOOR CATCH BR-BC-FC
190619	DOOR CATCH B-F-R
200923	DOOR GASKET
260223	M5X12 MSH/HD SCREW SPECIAL S/S
260238	M4 X 10 MUSH/HD SCREW
260247	SCREW TCB 5X16
260250	SCREW TB 5X20
260414	SELF-LOCKING NUT M5
260503	STAINL.STEEL FLAT WASHER D5 UN
260512	ST/ST GROWER WASHER D6
260542	WASHER D.5
320395	TOP PANEL FC
321807	DOOR HINGE FC MACHINES
322417	RIGHT GUIDE FC
322418	LEFT GUIDE FC
322941	DOOR FC54-543-544-HR
330233	FC DOOR TIE ROD
331764	FIXING PLATE FOR B-F DOOR GASK
341218	HINGE PIN B-F-G
341482	HOOD FC54-543-544-HR
342010	PIN FOR TIE ROD DOOR FC
351351	LEFT PANEL FC54-544-543-HR
351352	RIGHT PANEL FC54-543-544-HR
351353	FRONT PANEL FC
351526	LOWER FRONT PANEL
390150	LOWER BACK PANEL FC
390159	BACK PANEL FC54A
440201	RUBBER FOOT D.60X10
450821	SPRING CLIP FASTENER SNU 3634
461258	PLATE FC54E/A
463018	FC54 NAME

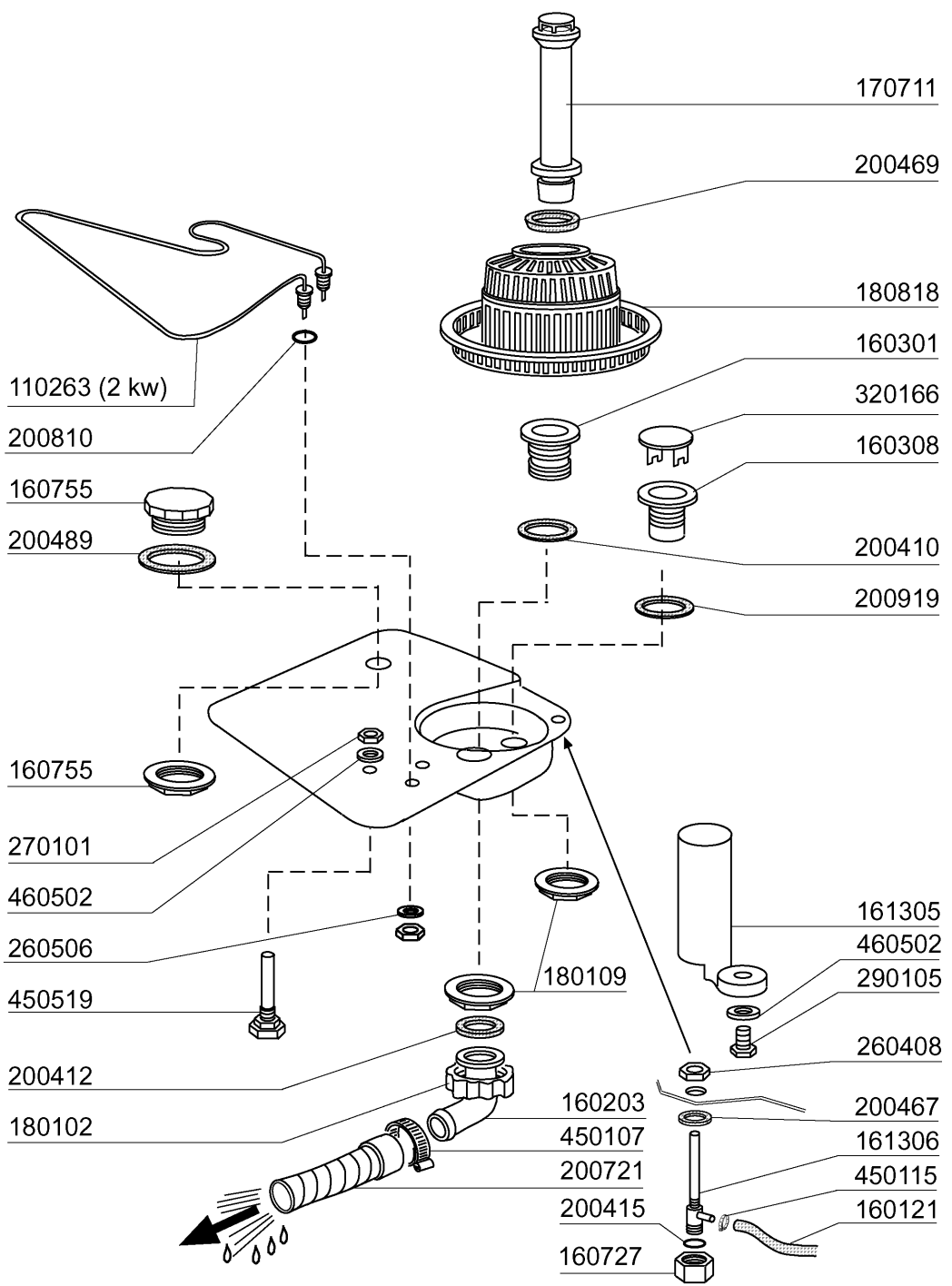

05 - 2002 | S. AG.

3 - Tank

CODE	DESCRIPTION
110263	TANK HEATER 2000W 230V
160121	HOSE EPDM D. 5 X 9
160203	ELBOW 1"1/2 N-S-F-C /DRAIN
160301	DRAIN OUTLET 1"1/2 C-S-N
160308	PUMP INLET HOSE FC
160727	PLUG 1/2 NTP CAP
160755	PLUG FOR MACHINES WITHOUT SOFT
161305	AIR CHAMBER F45-F80
161306	HOSE FOR AIR CHAMBER F45-80
170711	OVERFLOW PIPE FC
180102	DRAIN PIPE NUT 1"1/2 F45-55
180109	LOCK NUT 1 1/2"
180818	STRAINER FOR FC
200410	DRAIN OUTL.WASH.1 1/2"65X47X2
200412	GASKET DRAIN 11/2" 45X33X3
200415	AIR TRAP GASKET -F2 18,5X10X3
200467	DUTRAL GASKET F. AIR TRAP
200469	STAND PIPE O RING 45X35,5X7
200489	GASKET 81X68X3
200721	DRAIN HOSE 28X35 2MT.
200810	O-RING 2,62X9,92X15,6 F.GLASSW
200919	GASKET FOR SUCTION BASIN FC
260408	S/S NUTS D.12
260506	STAINL.STEEL FLAT WASHER D10
270101	HEXAGON LOCK NUT 1/2"
290105	BRASS-TE-PLUG 1/2"
320166	VORTEX BREAKER FOR FC MACHINES
450107	CLAMP FE ZN 38-50 H=12,2
450115	ELASTIC CLAMP D.8,3/7,8
450519	TANK THERMOSTAT SHIELD C-F
460502	GASKET 30X21X2

4 - Wash and rinse arms

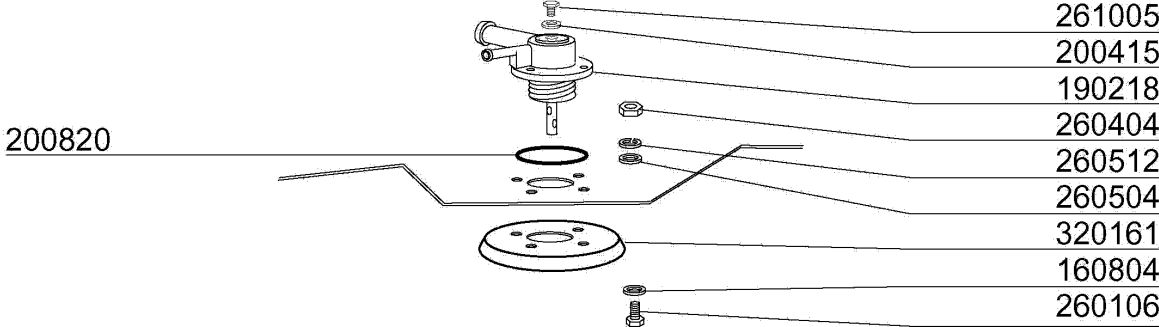

200820

- 261005
- 200415
- 190218
- 260404
- 260512
- 260504
- 320161
- 160804
- 260106

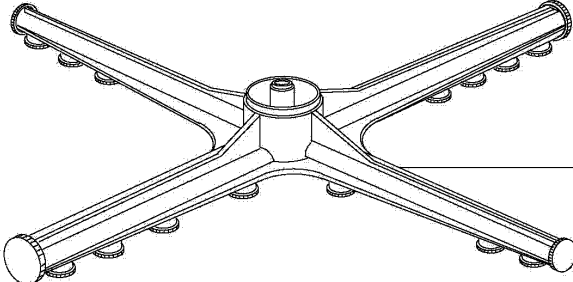

420552

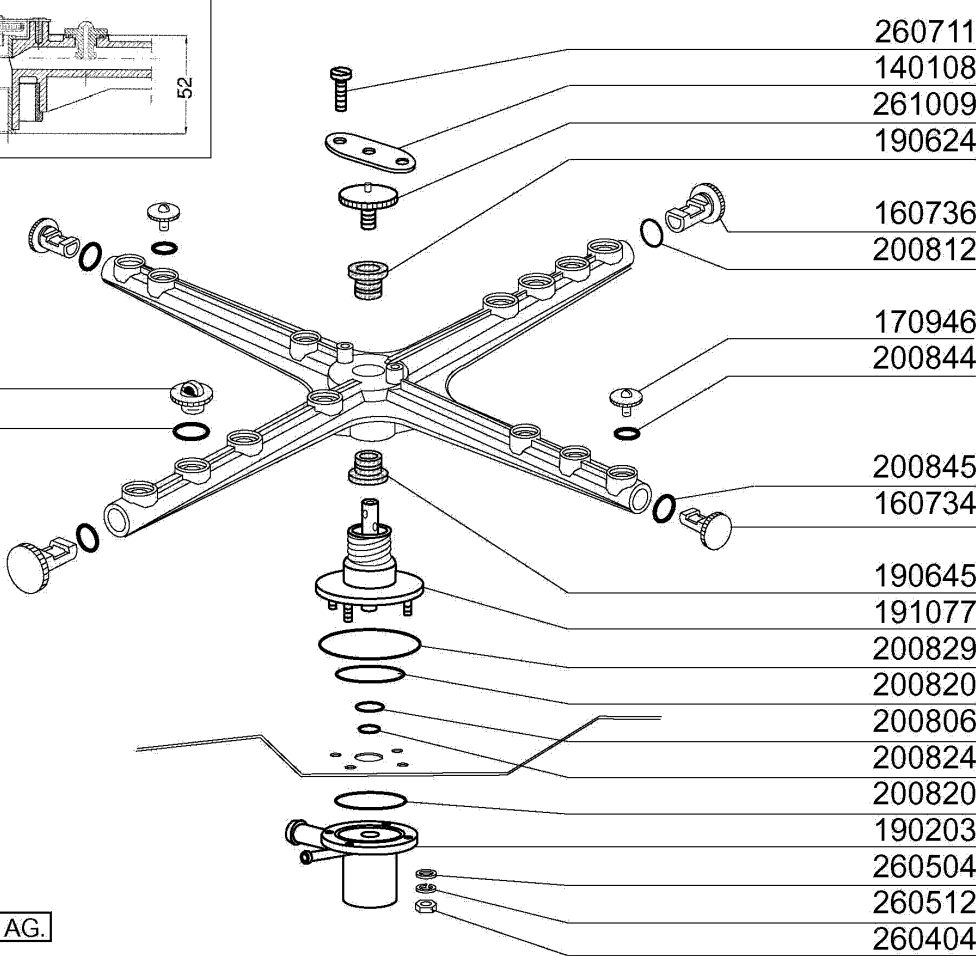
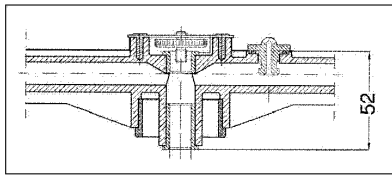

170947
200843

- 260711
- 140108
- 261009
- 190624
- 160736
- 200812
- 170946
- 200844
- 200845
- 160734
- 190645
- 191077
- 200829
- 200820
- 200806
- 200824
- 200820
- 190203
- 260504
- 260512
- 260404

06 - 2001 | S.AG.

4 - Wash and rinse arms

CODE	DESCRIPTION
140108	PLATE FOR WASH ARM
160734	END PLUGS RINSE ARM
160736	WASH ARM PLUG F45
160804	GASKET D.6
170946	RINSE JET/RINSE ARM B-F
170947	WASH JET/WASH ARM F45-80
190203	LOWER TEE WASH-RINSE F2-45-55-
190218	UPPER ARM SUPPORT
190624	BUSH FOR PLASTIC ARM F45
190645	LOWER BUSH FOR WASH ARM F
191077	LOWER WASH ARM SUPPORT FC54E
200415	AIR TRAP GASKET -F2 18,5X10X3
200806	O-RING 2,62X13,10X18,34
200812	O-RING 1,78X17,17X20,73
200820	O-RING151 46,99X5,33X57,6
200824	O-RING 1,78X12,42X15,98
200829	O-RING 81,92X92,58X5,33
200843	O RING 2X13X17
200844	O RING 2X9,5X13,5
200845	O RING 109 2,62X9,13X14,37
260106	SCREW TE 6X25
260404	STAINLESS STEEL NUTS D6 UNI 55
260504	ST/ST FLAT WASHER D6
260512	ST/ST GROWER WASHER D6
260711	SCREW 4,2X13 A2 DIN7972
261005	SCREW F. TEE UP.WASH F2-B41
261009	RETAIN.SCREW FOR WASH-RINSE AR
320161	UPPER WASH ARM PROTECTION
420552	ARM FC-ECONOMY

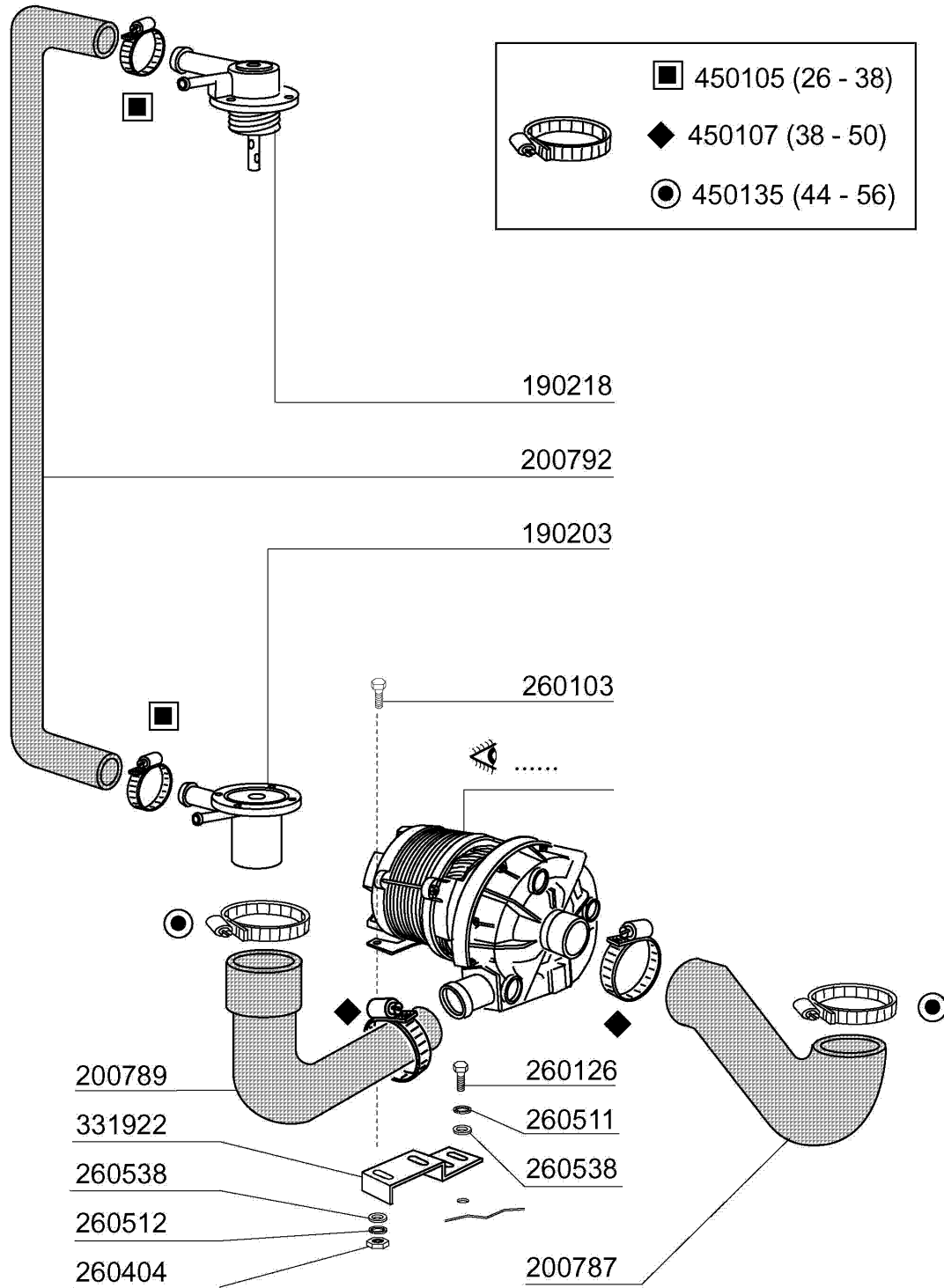

5 - Wash

CODE	DESCRIPTION
190203	LOWER TEE WASH-RINSE F2-45-55-
190218	UPPER ARM SUPPORT
200787	INLET HOSE FC53-FC544-FCHR
200789	OUTLET HOSE FC
200792	HOSE FOR UPPER/LOWER WASH FC54
260103	SCREW TE 6X12
260126	SCREW TE 5X12
260404	STAINLESS STEEL NUTS D6 UNI 55
260511	GROWER WASHER D.5
260512	ST/ST GROWER WASHER D6
260538	WASHER 18X6X1,5 ST/ST
331922	BRACKET F. PUMP "F"
450105	CLAMP FE ZN. 26-38 H=12,2
450107	CLAMP FE ZN 38-50 H=12,2
450135	CLAMP FE ZN. 44-56 H=12,2

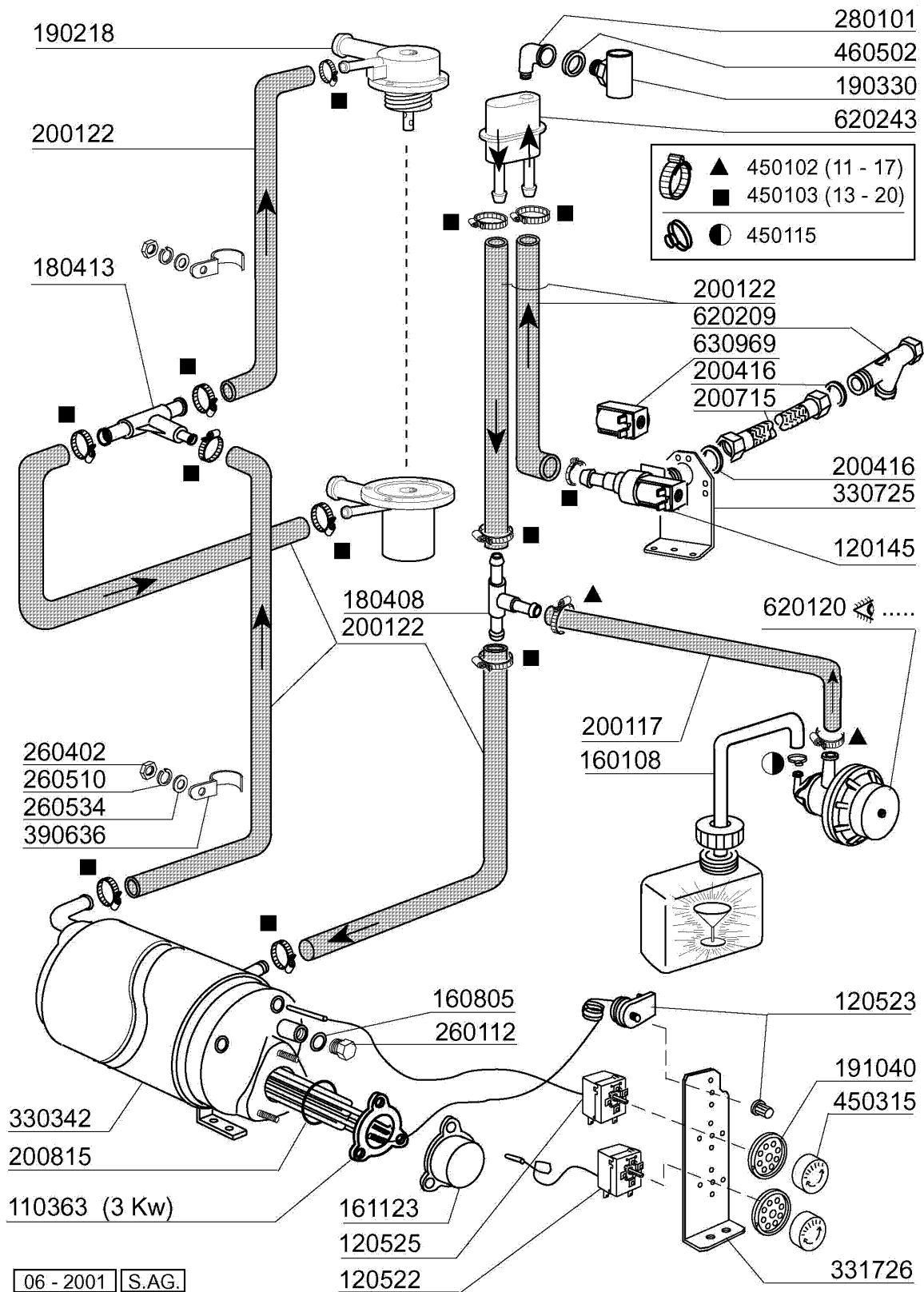

6 - Rinse

CODE	DESCRIPTION
110363	HEATING ELEMENT 3000W 230V
120145	SOLENOID VALVE 12 LT 1 WAY
120522	TANK THERMOSTAT 90Ø
120523	SAFETY THERMOSTAT 110Ø
120525	BOOSTER THERMOSTAT 2 TEMPERAT.
160108	INJECT.INLET HOSE D.8X5
160805	GASKET D.8
161123	HEAT.ELEMENT COVER H42 SNL
180408	TEE-NIPPLE F.INJECT.W/CENTR.RE
180413	TEE NIPPLE D.11,5 - RINSE ASSE
190218	UPPER ARM SUPPORT
190330	TEE FOR VAACUM BREAKER
191040	FRAME F.THERMOSTAT KNOB
200117	RUBBER HOSE 7X16
200122	HOSE 11X19
200416	GASKET D. 3/4"
200715	HOSE WATER INLET 2M STAINL.ST
200815	O-RING F. HEAT.ELEM.
260112	STAINLESS STEEL TE-SCREW 8X16
260402	STAINLESS STEEL NUT D4 UNI 55
260510	GROWER WASHER D.4
260534	WASHER
280101	CRANK F.F 1/2"
330342	BOILER C95-C155-C165
330725	STANDARD BRACKET F.SOLEN.VALV
331726	BRACKET FOR 3 THERMOSTATS
390636	BRACKET
450102	CLAMP FE ZN 11-17 H=9
450103	CLAMP FE ZN. 13-20 H=9
450115	ELASTIC CLAMP D.8,3/7,8
450315	KNOB F. THERMOSTAT 90Ø
460502	GASKET 30X21X2
620120	RINSE AID INJECTOR
620209	INLET WATER FILTER
620243	VACUUM BREAKER (WITHOUT KIT)
630969	COIL S4216 220/50HZ

631652 (50 Hz)

630413

630116

630222

630501

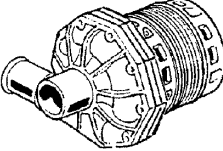

100399
220/240 V
50 Hz HP 0,6
Kw 0,45



631206
(10 μ F)

631683 \varnothing 93 (50 Hz)
631684 \varnothing 80 (60 Hz)

630419

630129

630240

630501

dalla matricola
a partir de la matr.
from serial no.
ab Seriennr.
despues la matr.
4755/04/01

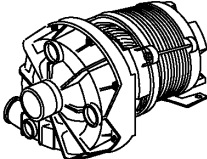

100740 220/240 V 50 Hz HP 0,6 - 4247
100744 220/200 V 60 Hz HP 0,6 - 4247
Kw 0,45



631206
(10 μ F)

7 - Pump

CODE	DESCRIPTION
100399	PUMP HP0,6 220-50HZ (100740)
100740	PUMP 0,6HP 220/240V 4247
100744	PUMP HP 0,6 200-220-60HZ
630116	-NO MORE AVAILABLE
630129	VOLUTE PUMP 0,5HP 2247
630222	COVER PUMP IB HP 0,4
630240	PUMP FLANGE 0,6HP-4247 FIR
630413	-NO MORE AVAILABLE
630419	PUMP GASKET 2247 0,5HP
630501	SEAL FOR PUMP HP 2-3-3,2
631206	CONDENSER 10MF. 450V 85C
631652	-NO MORE AVAILABLE
631683	PUMP IMPELLER 50HZ FIR 4247
631684	IMPELLER FOR PUMP 60 HZ

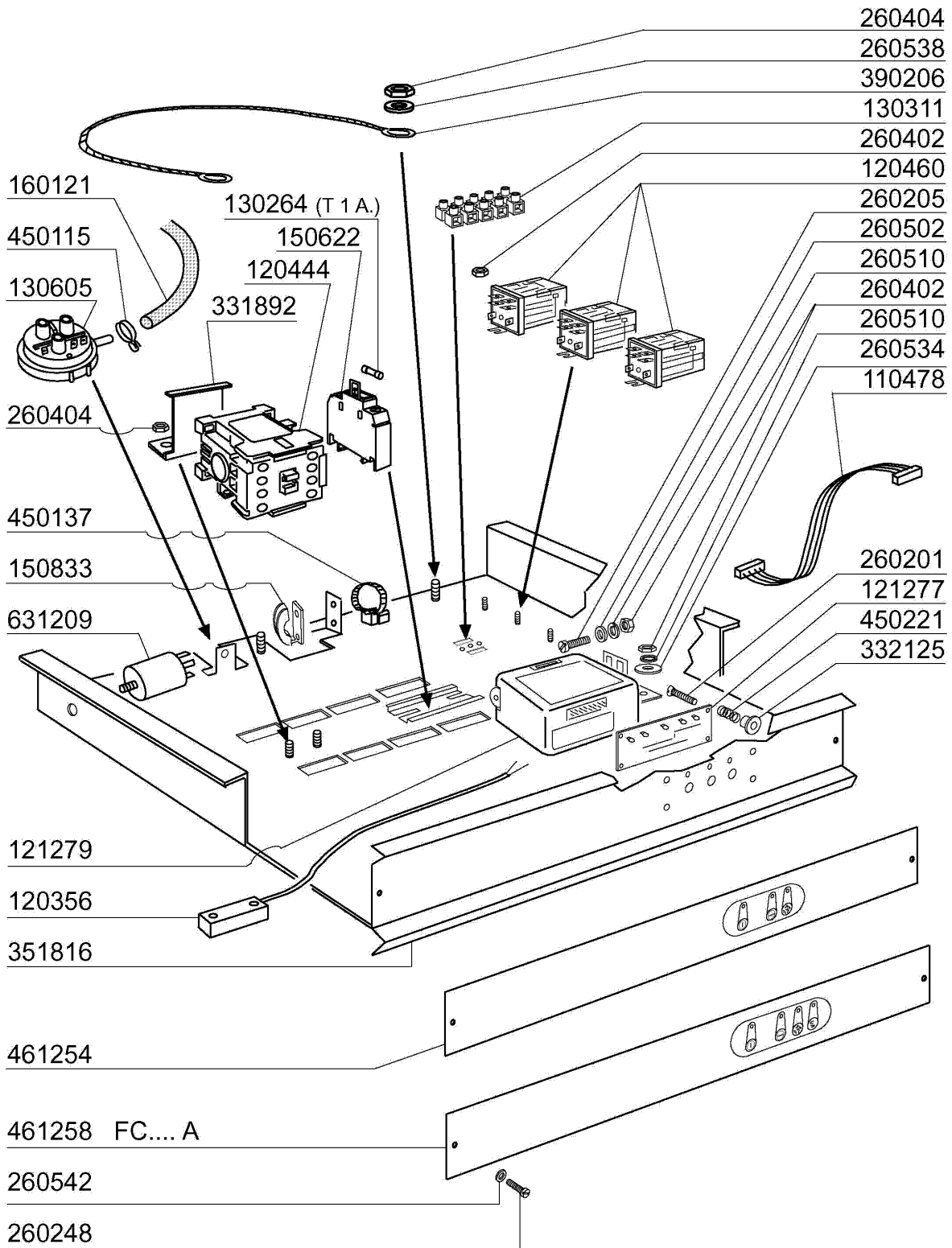

8 - Control box

CODE	DESCRIPTION
110478	FLAT CABLE FOR FC54E PCB
120356	DOOR MAGN.SWITCH
120444	CONTACTOR 9A 220V 50HZ
120460	RELAY 16A 220V
121277	CONTROL PANEL
121279	ELECTRONIC TIMER
130264	FUSE 5X20 1A
130311	TERMINAL BLOCK
130605	PRESSURE SWITCH 50-30 1 LEVEL
150622	FUSE HOLDER SIEMENS 1,5MM-6,3A
150833	CABLE HOLDER BC/BR
160121	HOSE EPDM D. 5 X 9
260201	SCREW TCP 3X10
260205	SCREW TCP 4X16
260248	SPECIAL SCREW TB 5X12
260402	STAINLESS STEEL NUT D4 UNI 55
260404	STAINLESS STEEL NUTS D6 UNI 55
260502	S/S FLAT WASHER D.4
260510	GROWER WASHER D.4
260534	WASHER
260538	WASHER 18X6X1,5 ST/ST
260542	WASHER D.5
331892	BRACKET
332125	-DISTANZ.SCHEDA COMANDI FC-E
351816	SUPPORT
390206	-TELAIO C1CM FE.VE.F1
450115	ELASTIC CLAMP D.8,3/7,8
450137	COLLAR CONNECTION WITH BASE 31
450221	SPRING FOR ELECTRONIC TIMER
461254	PLATE FC54E
461258	PLATE FC54E/A
631209	ANTI-NOISE FILTER



9 - Rinse aid injector

CODE	DESCRIPTION
160714	PLUG FOR RINSE AID INJECTOR MO
170701	LOCK NUT 1/2" F.INJECTOR
180306	NIPPLE F.RINSE AID INJECTOR
190107	COVER FOR RINSE AID DISPENSER
190108	VOLUTE FOR RINSE AID DISPENSER
190803	GASKET SUPPORT RING F.INJECT
191018	FILTER SUPPORT RINSE AID INJEC
200444	SUCTION VALVE RINSE INJECTOR
200816	O-RING 2,5X59,2X64,2 RINSE INJ
200825	O-RING 3X5X11 RINSE INJECTOR
200861	O-RING 14X18X2
260142	SCREW TE 4X16
260213	SCREW TCP 5X25
260402	STAINLESS STEEL NUT D4 UNI 55
260404	STAINLESS STEEL NUTS D6 UNI 55
260512	ST/ST GROWER WASHER D6
330543	FILTER RINSE AID INJECTOR D.17
340483	PISTON FOR RINSE AID DISPENSER
381105	DIAPHRAGME DISC
440405	GASKET FOR RINSE AID INJ.
450214	SPRING RINSE AID INJECTOR
620120	RINSE AID INJECTOR
630614	DIAPHRAGM RINSE INJECTOR

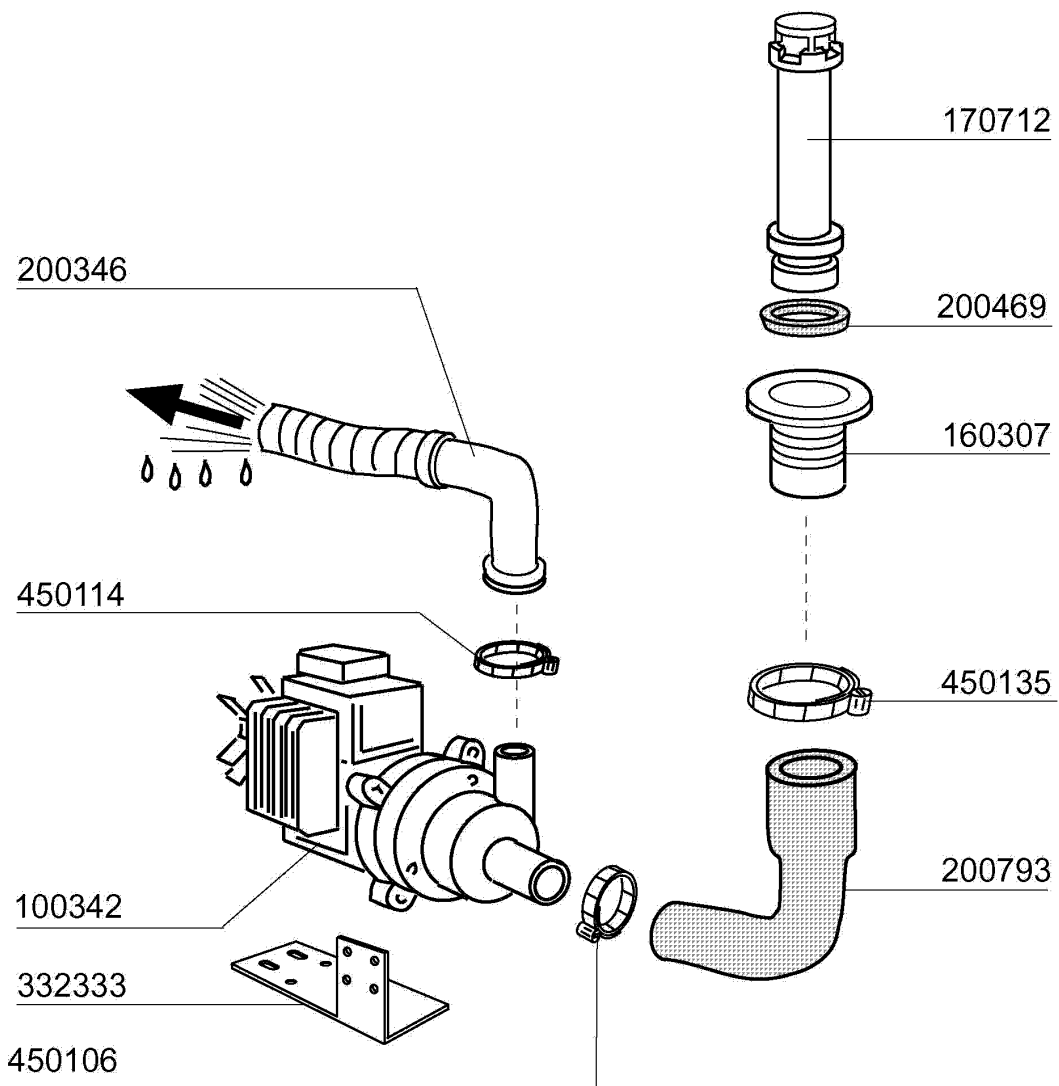

10 - Drain pump

CODE	DESCRIPTION
100342	DRAIN PUMP 100 W 220V
160307	DRAIN OUTLET FC
170712	OVERFLOW PIPE FOR DRAIN PUMP
200346	DRAIN HOSE GLASSWASHER
200469	STAND PIPE O RING 45X35,5X7
200793	DRAIN PUMP INLET HOSE FC
332333	BRACKET FOR DRAIN PUMP
450106	CLAMP FE ZN 32-44 H=12,2
450114	CLAMP FE ZN.22-32 H=12,2
450135	CLAMP FE ZN. 44-56 H=12,2

620242

200467

251213

260408

200607

180719

10 - 2000 | S. AG.

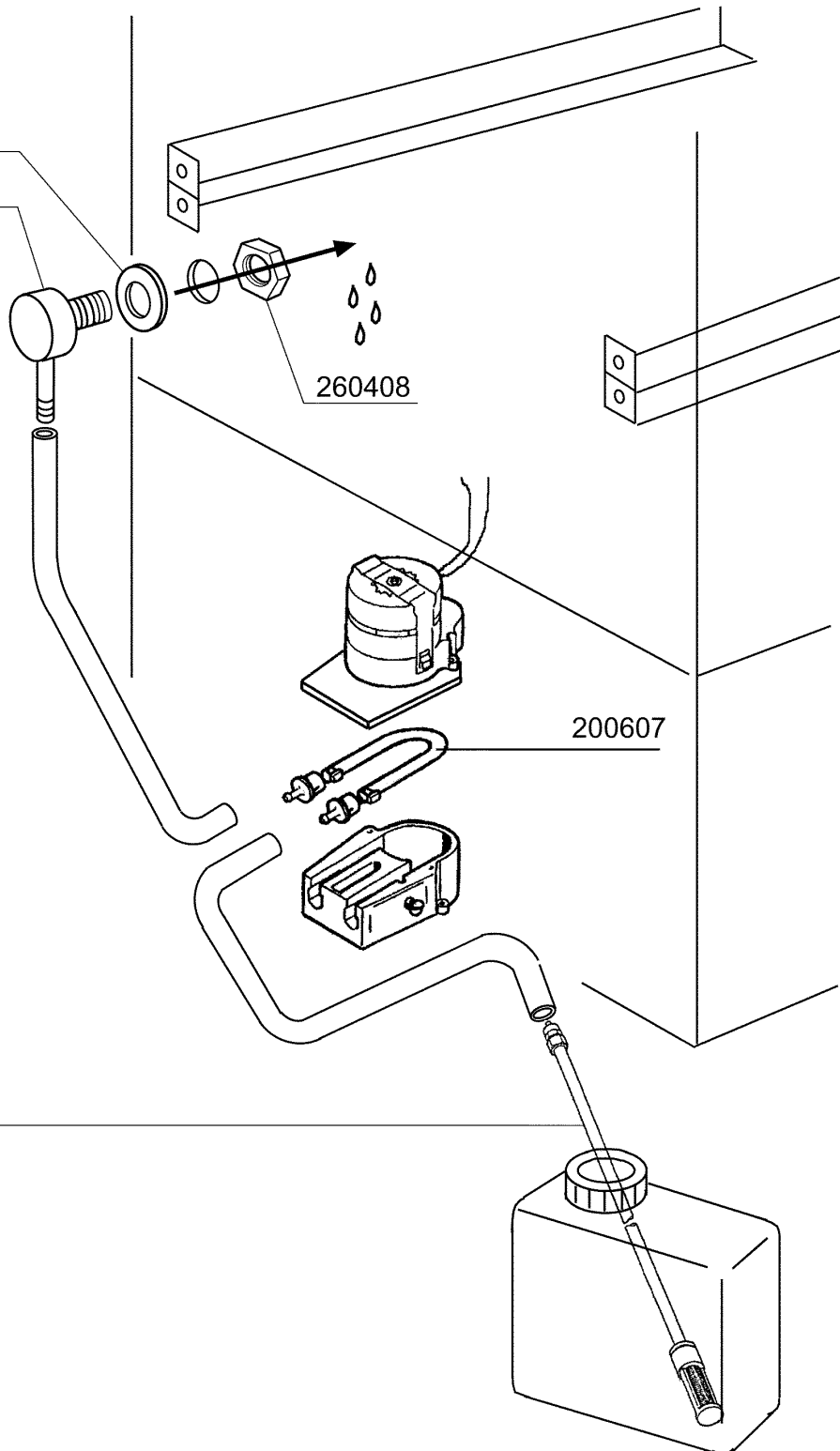

11 - Detergent dispenser

CODE	DESCRIPTION
180719	DETERGENT DISPENSER SUCTION HO
200467	DUTRAL GASKET F. AIR TRAP
200607	DETERGENT DISPENSER HOSE
251213	INJECTIOR S/S FOR DETERGENT IN
260408	S/S NUTS D.12
620242	DETERGENT INJECTOR (KIT)

12 - Wash and rinse arms

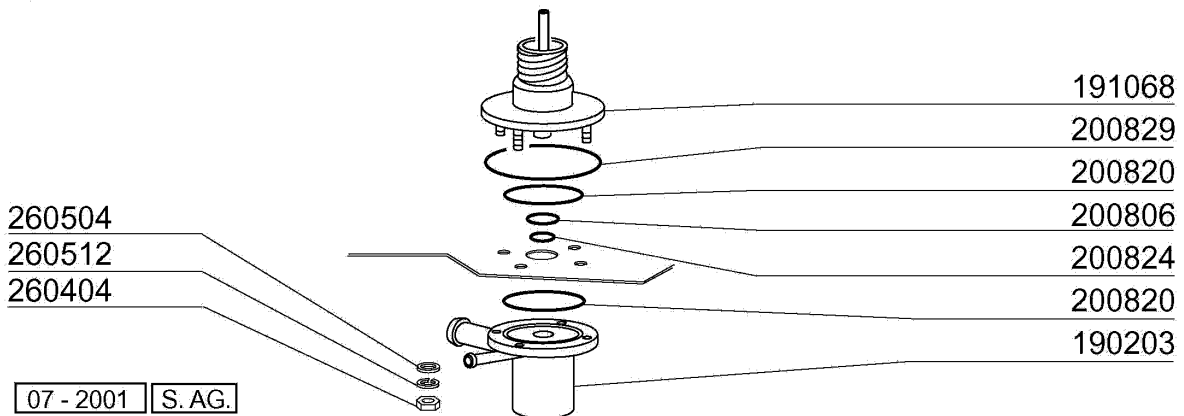
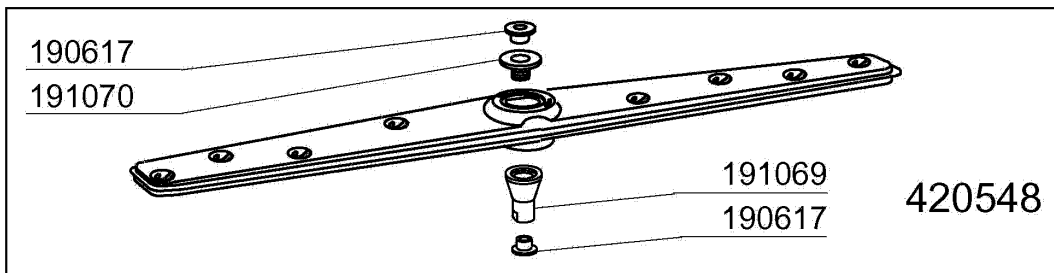
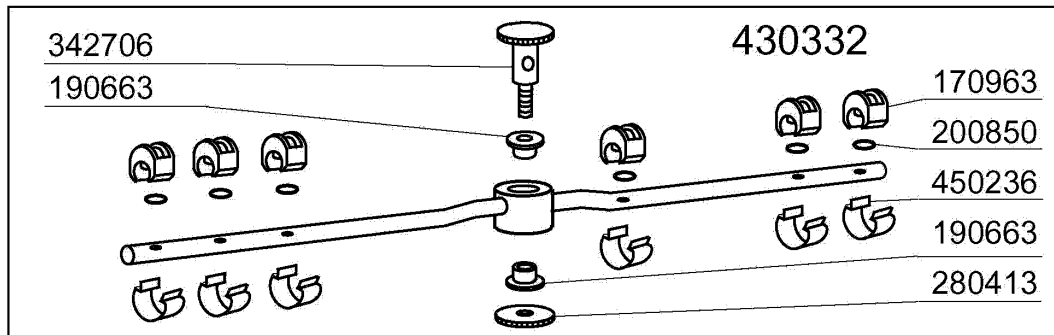
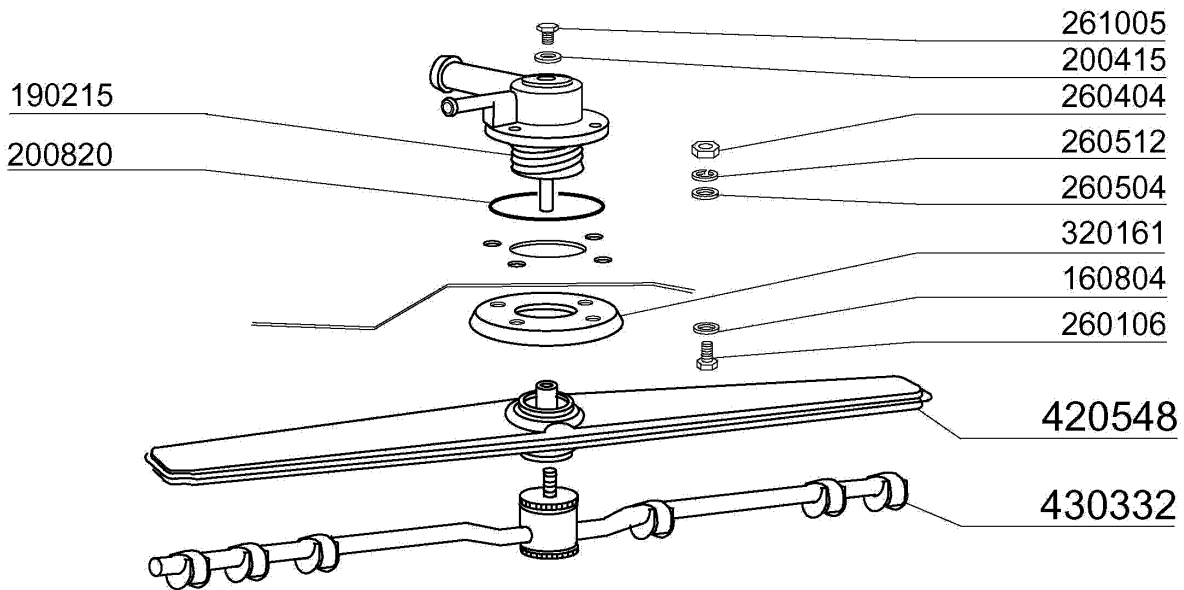

07 - 2001 S. AG.

12 - Wash and rinse arms

CODE	DESCRIPTION
160804	GASKET D.6
170963	RINSE JET X FC
190203	LOWER TEE WASH-RINSE F2-45-55-
190215	UPPER WASH/RINSE ARM SUPPORT F
190617	BUSH
190663	BUSH
191068	LOWER WASH ARM SUPPORT FC-MACH
191069	WASH ARM CENTER (FC - MACHINES
191070	LOCK NUT FOR WASH ARM CENTER (
200415	AIR TRAP GASKET -F2 18,5X10X3
200806	O-RING 2,62X13,10X18,34
200820	O-RING151 46,99X5,33X57,6
200824	O-RING 1,78X12,42X15,98
200829	O-RING 81,92X92,58X5,33
200850	O-RING
260106	SCREW TE 6X25
260404	STAINLESS STEEL NUTS D6 UNI 55
260504	ST/ST FLAT WASHER D6
260512	ST/ST GROWER WASHER D6
261005	SCREW F. TEE UP.WASH F2-B41
280413	RETAIN.LOCK NUT FOR FC RINSE A
320161	UPPER WASH ARM PROTECTION
342706	SHAFT
420548	FC WASH ARM (ST/ST)
430332	RINSE ARM FC 01/00
450236	SPRING FOR WASHER 170963